

# ***Color Camera Module***

---

## **Technical Manual**



**FCB-IX47A/IX47AP**  
**FCB-IX45A/IX45AP**

# Table of Contents

<b>Features .....</b>	<b>3</b>
<b>Locations of Controls .....</b>	<b>4</b>
<b>Basic Functions .....</b>	<b>5</b>
Overview of Functions .....	5
Eclipse .....	11
Spectral Sensitivity Characteristics .....	11
Vibration Specifications .....	11
Key Switch Circuitry .....	12
Key Function Specifications .....	13
Initial Settings, Custom Preset and Backup .....	15
Mode Condition .....	17
<b>Command List .....</b>	<b>20</b>
VISCA/RS-232C Commands .....	20
FCB-IX47A/IX47AP/IX45A/IX45AP Commands .....	26
<b>Specifications .....</b>	<b>43</b>
<b>Precautions .....</b>	<b>46</b>

# *Features*

- 18× optical zoom.
- Adopts a newly developed DSP for improved picture quality when using the digital zoom or the slow shutter.
- VISCA is a communications protocol, which enables the camera to be controlled remotely by commands from a host computer/controller.
- Six memory locations are provided to temporarily save and recall up to six sets of camera settings.
- The super HAD CCD features 380,000 effective picture elements and shooting with enhanced sensitivity. The minimum illumination required is 1.0 lux ( $1/60$  s (NTSC),  $1/50$  s (PAL)).

With consideration given to environmental protection, this module is designed to operate with low power consumption and incorporates lead-free circuit boards.

# Locations of Controls

## Main Unit

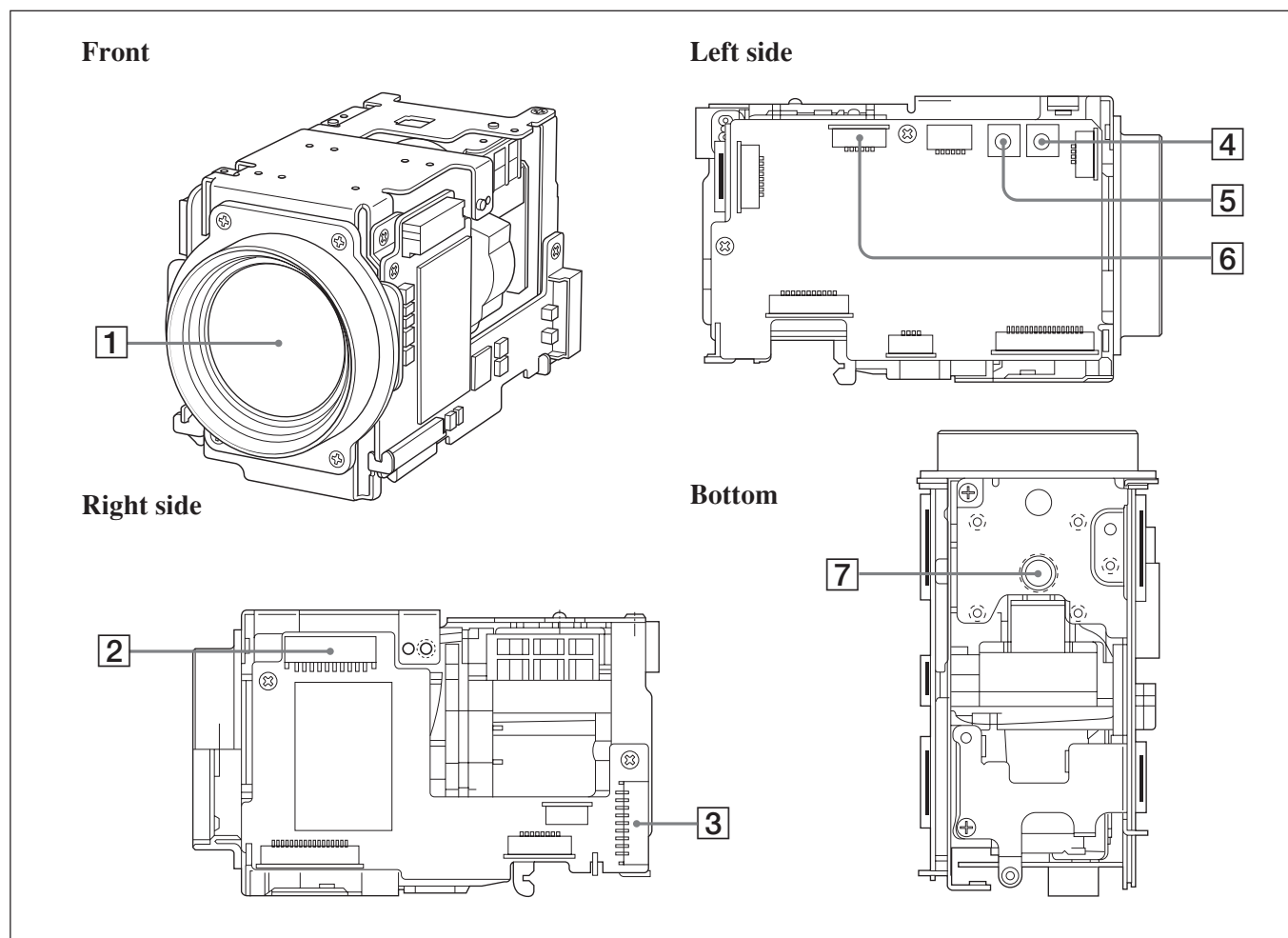

- 1 Lens
- 2 CN901 connector
- 3 CN903 connector
- 4 TELE button

- 5 WIDE button
- 6 CN701 connector
- 7 Tripod screw holes

When a tripod is used, please use 10 mm ( $13/32$  in.) screws to attach it to the camera. Also, please be sure to attach the tripod securely.

# Basic Functions

## Overview of Functions

VISCA commands are the basis of camera control.

### Timing Chart

As VISCA Command processing can only be carried out one time in a Vertical cycle, it takes the maximum 1V cycle time for an ACK/Completion to be returned. If the Command ACK/Completion communication time can be cut shorter than the 1V cycle time, then every 1V cycle can receive a Command.

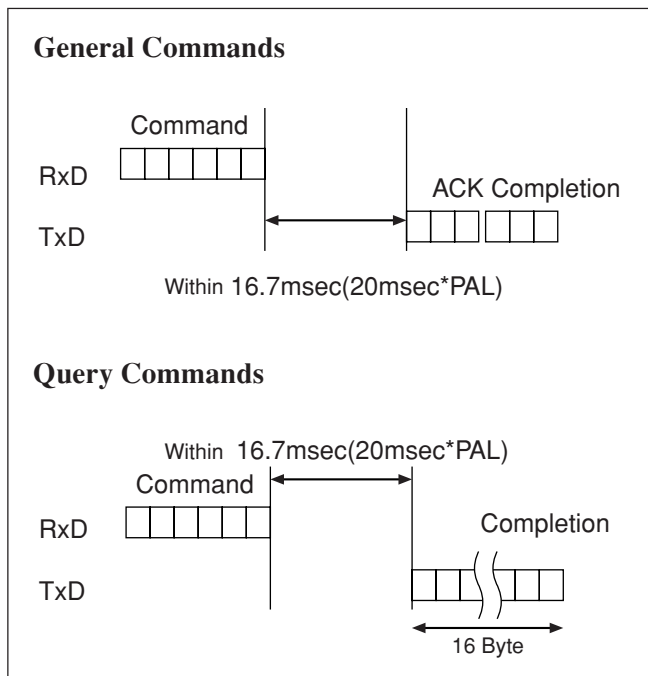

### General

#### • Power On/Off

Powers the camera on and off. When the power is off, the camera is able to accept only the lowest level of VISCA Commands; the display and other features are turned off.

#### • I/F clear

Clears the Command buffer of the FCB-IX47A/IX47AP/IX45A/IX45AP. Clearing the buffer can also be carried out from the control application software when the power is on.

#### • Address set

VISCA is a protocol, which normally can support a daisy chain of up to seven attached devices. Therefore, whenever a camera is connected for the first time, be sure to use the address set to confirm the address.

#### • ID Write

Sets the camera ID.

#### • Mute

Blanks the screen and sends out a synchronizing signal.

#### • Lens Initialization

Initializes the zoom and focus of the lens. Even when power is already on, it initializes the zoom and the focus.

#### • Comp Scan

A pixel blemish-masking feature is used to reevaluate overall CCD pixel blemishes and mask severely flawed pixels automatically upon receiving the COMP SCAN command. This feature helps to mask the flaws found in CCD imagers, even after the camera has been powered on for some time.

---

## Zoom

The FCB-IX47A/IX47AP/IX45A/IX45AP employs an 18× optical zoom lens combined with a digital zoom function allowing you to zoom up to 72×.

**Lens specifications:** Optical 18×, f = 4.1 to 73.8 mm (F1.4 to F3.0)

The horizontal angle of view is approximately 48 degrees (wide end) to 2.7 degrees (tele end). Digital Zoom enlarges the center of the subject by expanding each image in both the vertical and horizontal directions. When 72× zoom is used, the number of effective picture elements in each direction reduces to  $\frac{1}{4}$  and the overall resolution deteriorates.

You can activate the zoom in the following two ways:

- **By pressing the TELE or WIDE button on the camera itself.**

- **Using a VISCA Command**

- **Using Standard Mode**

- **Using Variable Mode**

- There are eight levels of zoom speed.

- **Direct Mode**

- Setting the zoom position enables quick movement to the designated position.

- **Digital Zoom ON/OFF**

- *In these standard and variable Speed Modes, it is necessary to send a "Stop Command" to stop the zoom operation.*

- The Zoom Mode supports a Combined Mode and a Separate Mode.

- **Combined Mode**

- This is the previously existing zoom method. After the optical zoom has reached its maximum level, the camera switches to Digital Zoom Mode.

- **Separate Mode**

- In this mode, Optical Zoom and Digital Zoom can be operated separately. You can use digital zoom magnification at any time from within any level of optical magnification.

---

## Focus

Focus has the following modes, all of which can be set using VISCA Commands.

- **Auto Focus Mode**

- The minimum focus distance is 10 mm at the optical wide end and 800 mm at the optical tele end, and is independent of the digital zoom.

The AutoFocus (AF) function automatically adjusts the focus position to maximize the high frequency content of the picture in a center measurement area, taking into consideration the high luminance and strong contrast components.

- **Normal AF Mode**

- This is the normal mode for AF operations.

- **Interval AF Mode**

- The mode used for AF movements carried out at defined intervals. The time intervals for AF movements and for the timing of the stops can be set in one-second increments using the Set Time Command. The initial value for both is set to five seconds.

- **Zoom Trigger Mode**

- When the zoom is changed with the TELE button, WIDE button, VISCA Zoom commands or key switches, the pre-set value (initially set at 5 seconds) becomes that for AF Mode. Then, it returns to Manual Focus mode.

AF sensitivity can be set to either HIGH or LOW.

- **HIGH**

- Reaches the highest focus speed quickly. Use this when shooting a subject that moves frequently. Usually, this is the most appropriate mode.

- **LOW**

- Improves the stability of the focus. When the lighting level is low, the AF function does not take effect, even though the brightness varies, contributing to a stable image.

**When used for 24 hours continuously, initialization of lens system once a day is recommended because this will make the life of lens longer. The Initialize Lens Command takes a little less than 3 seconds to initialize the focus and zoom.**

- **Manual Focus Mode**

- Manual Focus has both a Standard Speed Mode and a Variable Speed Mode. Standard Speed Mode focuses at a fixed rate of speed. Variable Speed Mode has eight speed levels that can be set using a VISCA Command.

- **One Push Trigger Mode**

- When a Trigger Command is received, the lens moves to adjust the focus for the subject. The focus lens then holds the same position until the next Trigger Command is input.

- **Infinity Mode**

- The lens is forcibly moved to a position suitable for an unlimited distance.

- **Near Limit Mode**

- Can be set in a range from 1000 ( $\infty$ ) to C000 (10 mm).

## White Balance

White Balance has the following modes, all of which can be set using VISCA Commands.

- **Auto White Balance**

This mode computes the white balance value output using color information from the entire screen. It outputs the proper value using the color temperature radiating from a black subject based on a range of values from 3000 to 7500K.

This mode is the default setting.

- **ATW**

Auto Tracing White balance (2000 to 10000 K)

- **Indoor**

3200 K Base Mode

- **Outdoor**

5800 K Base Mode

- **One Push WB**

The One Push White Balance mode is a fixed white balance mode that may be automatically readjusted only at the request of the user (One Push Trigger), assuming that a white subject, in correct lighting condition, and occupying more than  $\frac{1}{2}$  of the image, is submitted to the camera.

One Push White Balance data is lost when the power is turned off. If the power is turned off, reset the One Push White Balance.

- **Manual WB**

Manual control of R and B gain, 256 steps each

## Automatic Exposure Mode

The variety of AE functions, which allow video signal to output the optimum image for subjects from low light conditions to bright light conditions, are available.

- **Full Auto**

Auto Iris and Gain, Fixed Shutter Speed (NTSC:  $\frac{1}{60}$  s, PAL:  $\frac{1}{50}$  s)

- **Shutter Priority**<sup>1)</sup>

Variable Shutter Speed, Auto Iris and Gain ( $\frac{1}{1}$  to  $\frac{1}{10,000}$  s, 22 steps, std. shutter: 16 steps, slow shutter: 6 steps)

- **Iris Priority**

Variable Iris (F1.4 to Close, 18 steps), Auto Gain and Shutter speed

- **Manual**

Variable Shutter, Iris and Gain

- **Bright**

Variable Iris and Gain (Close to F1.4, 17 steps at 0 dB: F1.4, 15 steps from 0 to 28 dB)

## AE – Shutter Priority

The shutter speed can be set freely by the user to a total of 22 steps – 16 high speeds and 6 low speeds. When the slow shutter is set, the speed can be  $\frac{1}{30}$ ,  $\frac{1}{15}$ ,  $\frac{1}{8}$ , or  $\frac{1}{4}$  s. The picture output is read at a normal rate from the memory. The memory is updated at a low rate from the CCD. AF capability is low.

In high speed mode, the shutter speed can be set up to  $\frac{1}{10,000}$  s. The iris and gain are set automatically, according to the brightness of the subject.

Data	NTSC	PAL
15	10000	10000
14	6000	6000
13	4000	3500
12	3000	2500
11	2000	1750
10	1500	1250
0F	1000	1000
0E	725	600
0D	500	425
0C	350	300
0B	250	215
0A	180	150
09	125	120
08	100	100
07	90	75
06	60	50
05	30	25
04	15	12
03	8	6
02	4	3
01*	2	2
00*	1	1

\* For AE-Manual only.

### Note

The Slow Shutter function is not supported by the FCB-IX45A/IX45AP.

## AE – Iris Priority

The iris can be set freely by the user to 18 steps between F1.4 and Close.

The gain and shutter speed are set automatically according to the brightness of the subject.

Data	Setting value	Data	Setting value
11	F1.4	08	F6.8
10	F1.6	07	F8.0
0F	F2.0	06	F9.6
0E	F2.4	05	F11
0D	F2.8	04	F14
0C	F3.4	03	F16
0B	F4.0	02	F19
0A	F4.8	01	F22
09	F5.6	00	CLOSE

1) Flicker can be eliminated by setting shutter to:

→  $\frac{1}{100}$  s for NTSC models used in countries with a 50 Hz power supply frequency.

→  $\frac{1}{120}$  s for PAL models used in countries with a 60 Hz power supply frequency.

**AE – Manual**

The shutter speed (22 steps), iris (18 steps) and gain (16 steps) can be set freely by the user.

**AE – Bright**

The bright control function adjusts both the gain and iris using an internal algorithm according to a brightness level freely set by the user. Exposure is controlled by gain when dark, and by iris when bright. As both gain and iris are fixed, this mode is used when exposing at a fixed camera sensitivity. When switching from Full Auto or Shutter Priority Mode to Bright Mode, the current status will be retained for a short period of time.

Only when the AE mode is set to “Full Auto” or “Shutter Priority,” the user can switch it to “Bright.”

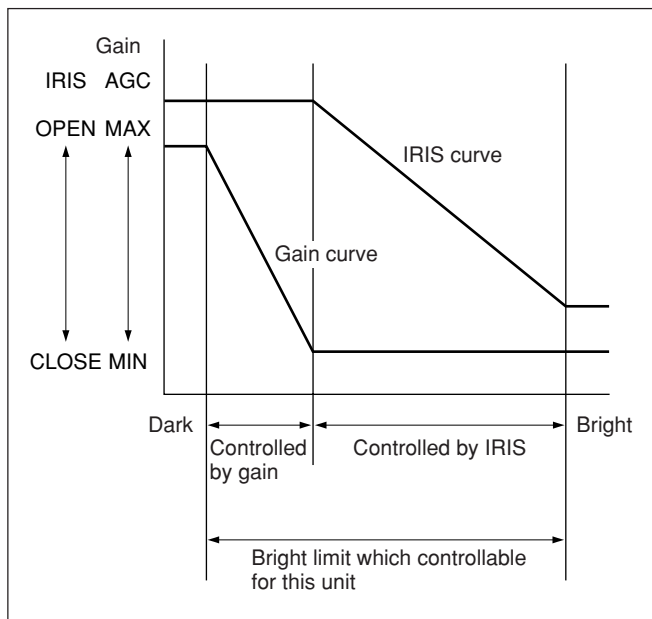

Data	Iris	Gain	Data	Iris	Gain
1F	F1.4	28 dB	0F	F2.0	0 dB
1E	F1.4	26 dB	0E	F2.4	0 dB
1D	F1.4	24 dB	0D	F2.8	0 dB
1C	F1.4	22 dB	0C	F3.4	0 dB
1B	F1.4	20 dB	0B	F4.0	0 dB
1A	F1.4	18 dB	0A	F4.8	0 dB
19	F1.4	16 dB	09	F5.6	0 dB
18	F1.4	14 dB	08	F6.8	0 dB
17	F1.4	12 dB	07	F8.0	0 dB
16	F1.4	10 dB	06	F9.6	0 dB
15	F1.4	8 dB	05	F11	0 dB
14	F1.4	6 dB	04	F14	0 dB
13	F1.4	4 dB	03	F16	0 dB
12	F1.4	2 dB	02	F19	0 dB
11	F1.4	0 dB	01	F22	0 dB
10	F1.6	0 dB	00	CLOSE	0 dB

When switching from the Shutter Priority mode to the Bright mode, the shutter speed set in the Shutter Priority mode is maintained.

**Spot Exposure Mode**

In Full Auto AE, the level for the entire screen is computed and the optimum Auto Iris and Gain levels are determined. In Spot AE, a particular section of the subject can be designated, and then that portion of the image can be weighted and a value computed so that Iris and Gain can be optimized to obtain an image. For example, in an image with a lot of movement and with varying levels of brightness, portions without much change can be designated as such a “spot,” and changes to the screen can be minimized in that area. As shown in the diagram below, a range of 16 blocks vertically and 16 blocks horizontally can be designated.

In the case where the center is designated (shown in black), the level is computed along with a weighted value for the surrounding block (shaded), including the specified portions; and then the Gain and Iris are set. The value of the designated portions and the surrounding areas should be calculated as 90% and the rest should be set to 10%.

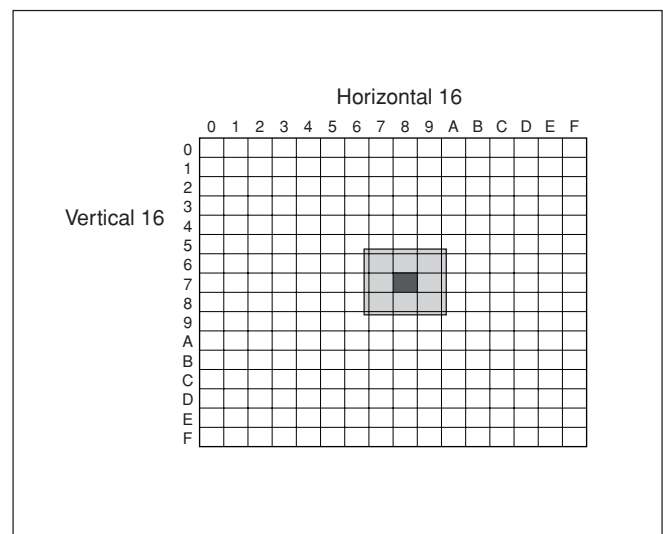



---

## Exposure Compensation

Exposure compensation is a function which offsets the internal reference brightness level used in the AE mode by steps of 1.5 dB.

Data	Step	Setting value
0E	7	10.5 dB
0D	6	9 dB
0C	5	7.5 dB
0B	4	6 dB
0A	3	4.5 dB
09	2	3 dB
08	1	1.5 dB
07	0	0 dB
06	-1	-1.5 dB
05	-2	-3 dB
04	-3	-4.5 dB
03	-4	-6 dB
02	-5	-7.5 dB
01	-6	-9 dB
00	-7	-10.5 dB

---

## Aperture Control

Aperture control is a function which adjusts the enhancement of the edges of objects in the picture. There are 16 levels of adjustment, starting from “no enhancement.” When shooting text, this control may help by making the text sharper.

---

## Back Light Compensation

When the background of the subject is too bright, or when the subject is too dark due to shooting in the AE mode, back light compensation will make the subject appear clearer.

---

## Slow Shutter – Auto/Manual

When the Slow Shutter is set to “Auto,” this ensures that the slow shutter is engaged automatically when the brightness drops. This occurs only when the AE mode is set to “Full Auto.”

“Slow Shutter Manual” is the factory setting.

### Note

This function is not supported by the FCB-IX45A/IX45AP.

---

## Camera ID

The ID can be set up to 65,536 (0000 to FFFF). As this will be memorized in the nonvolatile memory inside the camera, data will be saved regardless of whether it has been backed up.

---

## Effect

It consists of the following functions.

- **Neg. Art:** Negative/Positive Reversal
- **Black White:** Monochrome Image

---

## Others

### Mirror Image

The video output from the camera can be reversed left and right using this function.

### Freeze

This function captures an image in the field memory of the camera so that this image can be output continuously.

*Because communication inside the camera is based on V cycle, the captured image is always the one 3V to 4Vs after the sending of a Command. Thus, you can not specify a time period after sending EVEN, ODD or a Command.*

### Note

This function is not supported by the FCB-IX45A/IX45AP.

## Memory (Position Preset)

Using the position preset function, 6 sets of camera shooting conditions can be stored and recalled.

This function allows you to achieve the desired status instantly even without adjusting the following items each time:

- Zoom Position
- Digital Zoom On/Off
- Focus Auto/Manual
- Focus Position
- AE Mode
- Shutter control parameters
- Bright Control
- Iris control parameters
- Gain control parameters
- Exposure Compensation On/Off
- Exposure Level
- Backlight Compensation On/Off
- Slow Shutter Auto/Manual
- White Balance Mode
- R/B Gain
- Aperture
- ICR Shoot On/Off

## Custom Preset

As with the position preset function, the camera shooting conditions can be stored and recalled. The settings are recalled when the power is turned on. For setting items, refer to the “Initial Settings, Custom Preset and Backup” section on page 15.

## Title Display

The camera can be given a title containing up to 20 characters such as “ENTRANCE” or “LOBBY”. The position of the first character (horizontal, vertical) of the title, blinking state, and color can also be changed.

Vposition	00 to 0A	
Hposition	00 to 17	
Blink	00: Does not blink	
	01: Blinks	
Color	00	White
	01	Yellow
	02	Violet
	03	Red
	04	Cyan
	05	Green
	06	Blue

00	01	02	03	04	05	06	07
A	B	C	D	E	F	G	H
08	09	0a	0b	0c	0d	0e	0f
I	J	K	L	M	N	O	P
10	11	12	13	14	15	16	17
Q	R	S	T	U	V	W	X
18	19	1a	1b	1c	1d	1e	1f
Y	Z	&		?	!	1	2
20	21	22	23	24	25	26	27
3	4	5	6	7	8	9	0
28	29	2a	2b	2c	2d	2e	2f
À	È	Ì	Ò	Ù	Á	É	Í
30	31	32	33	34	35	36	37
Ó	Ú	Â	Ê	Ô	Æ	Œ	Ã
38	39	3a	3b	3c	3d	3e	3f
Õ	Ñ	Ç	ß	Ä	Ï	Ö	Ü
40	41	42	43	44	45	46	47
Å	\$	₣	¥	DM	£	ı	i
48	49	4a	4b	4c	4d	4e	4f
ø	“	:	‘	.	,	/	-

## Date and Time Display

The date and time (accuracy: ±30 s/month) can be displayed on the video monitor using a Display command.

# Eclipse

When designing the housing, refer to the dimensional allowance as shown in the figure below.

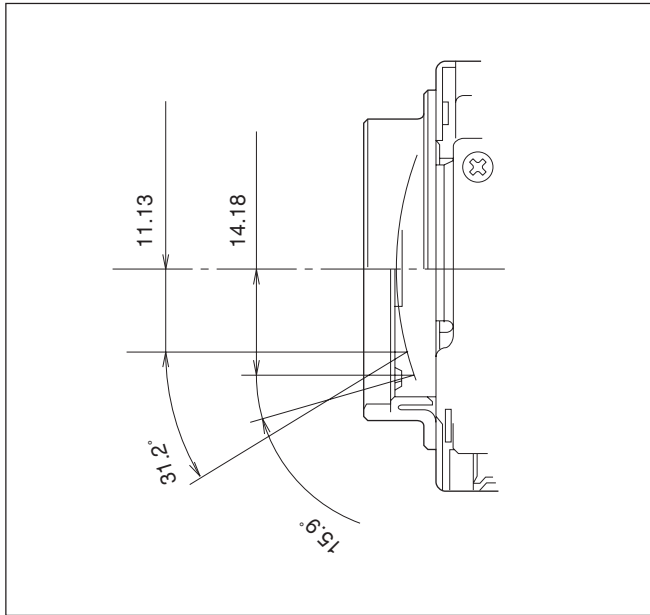

# Vibration Specifications

## Test Method (Random vibration)

- Fix the camera at the four fixation points of the base using M2 screws.
- Perform the random vibration test under the following conditions in the X, Y and Z directions for 20 minutes in each direction.
- The camera vibration specification is to have no malfunction after this test.

Power spectrum density	5 to 50 Hz	4.14 m <sup>2</sup> /s <sup>3</sup>	{0.043 G <sup>2</sup> /Hz}
	50 to 100 Hz	-36 dB/oct	
Effective overall value	14.3 m/s <sup>2</sup> {1.46 G}		
Test time	20 minutes		

# Spectral Sensitivity Characteristics

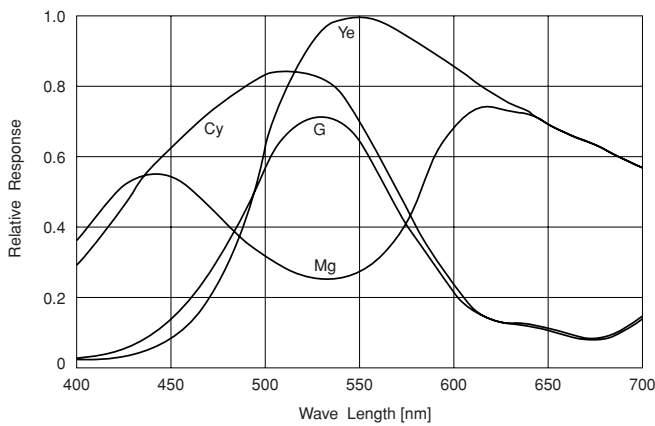

# Key Switch Circuitry

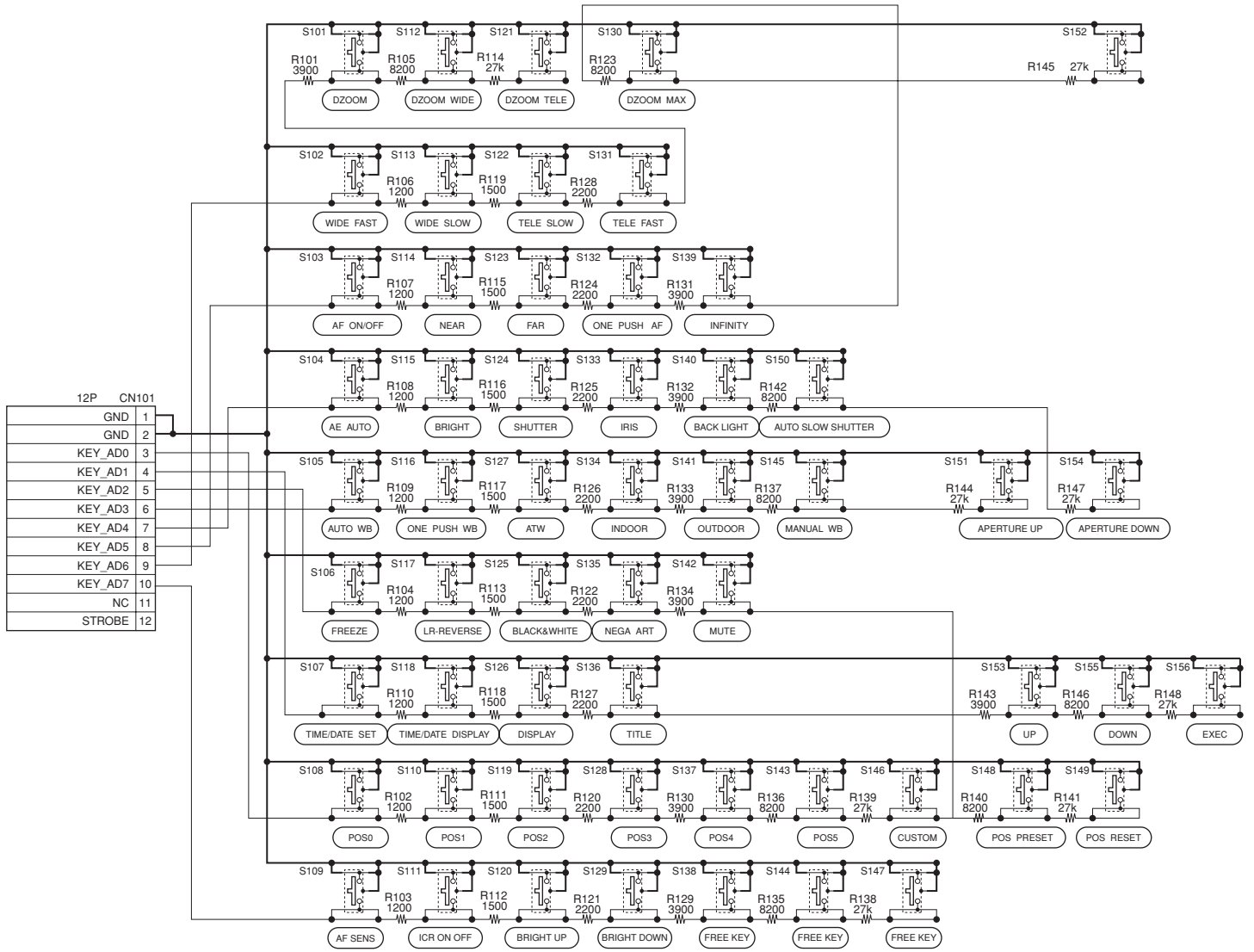

# Key Function Specifications

Classification	Name	Function	Button operation	Mode display
ZOOM	WIDE	Move ZOOM to WIDE side quickly.	Pressing repeatedly allowed.	ZOOM bar displayed for 3 s.
	WIDE SLOW	Move ZOOM to WIDE side slowly.	Pressing repeatedly allowed.	ZOOM bar displayed for 3 s.
	TELE SLOW	Move ZOOM to TELE side slowly.	Pressing repeatedly allowed.	ZOOM bar displayed for 3 s.
	TELE FAST	Move ZOOM to TELE side quickly.	Pressing repeatedly allowed.	ZOOM bar displayed for 3 s.
D-ZOOM	DZOOM	Turn on/off the mode for shifting from optical MAX to electronic ZOOM in combined mode.	Switch on/off.	ZOOM bar displayed for 3 s.
	DZOOM WIDE	Move the electronic ZOOM to WIDE side in separate mode.	Pressing repeatedly allowed.	ZOOM bar displayed for 3 s.
	DZOOM TELE	Move the electronic ZOOM to TELE side in separate mode.	Pressing repeatedly allowed.	ZOOM bar displayed for 3 s.
	DZOOM MAX	Switch the electronic ZOOM between 1× and MAX in separate mode.	Switch between 1× and MAX magnification.	ZOOM bar displayed for 3 s.
FOCUS	AF	Switch between Auto Focus and Manual Focus.	Switch between Auto and Manual.	Manual F indication
	NEAR	Move focus to NEAR side in Manual Focus mode.	Pressing repeatedly allowed.	Near indication
	FAR	Move focus to FAR side in Manual Focus mode.	Pressing repeatedly allowed.	Far indication
	ONE PUSH AF	Perform AF operation once in Manual Focus mode.	Request One Push AF.	Manual F indication flashes while request is made.
	INFINITY	Move focus forcibly to Infinity resulting in Manual Focus mode, regardless of the current focus mode.	Request Infinity.	Far indication
AE	AE AUTO	Switch to AE FULL Auto mode.	Request AE Full Auto.	No display
	BRIGHT	Switch to variable brightness mode (BRIGHT), depending on the conditions for mode shifting.	Request Bright mode. Pressing Up/Down key repeatedly allowed.	Bright bar display
	SHUTTER	Shutter priority AE mode	Request shutter priority AE mode.	Shutter code display
	IRIS	Iris priority AE mode	Request iris priority AE mode.	Iris code display
	BACK LIGHT	Switch backlight on/off.	Switch on/off.	Backlight indication
WB	AUTO WB	Switch to AUTO WB mode.	Request Auto WB mode.	No display
	ONE PUSH WB	Switch to One Push WB mode when pressed once and capture data when pressed 2nd time.	Request One Push WB mode and trigger.	One Push indication flashes at 0.8 Hz before capturing data, at 3.2 Hz during capturing, and stays lit after capturing.
	ATW	Switch to ATW mode.	Request AWB mode.	ATW display
	INDOOR	Enable WB at 3200K in INDOOR mode.	Request Indoor mode.	Indoor indication
	OUTDOOR	Enable WB at 5800K in OUTDOOR mode.	Request Outdoor mode.	Outdoor indication
	MANUAL WB	Switch to Manual WB mode. Enable R control when pressed once and enable B control when pressed 2nd time. Switchable with UP/DOWN key.	Switch between R control and B control in manual WB mode./Pressing Up/Down key repeatedly allowed.	“WB-MAN” (character display)

Classification	Name	Function	Button operation	Mode display
FEATURE	FREEZE*1	Capture still image.	Switch on/off.	FREEZE indication
	LR-REVERSE	Horizontal reversal	Switch on/off.	Horizontal reversal indication
	BLACK & WHITE	Black-and-white output	Switch on/off.	B&W display
	NEGA ART	Negative art output	Switch on/off.	Neg Art display
	MUTE	Mute video output	Switch on/off.	“MUTE” (character display)
DISPLAY	TIME/DATE SET	Set date and time. Start setting with Exec, make settings with Up/Down key, and confirm settings with Exec.	Request setting. → Setting is started with Exec. Pressing Up/Down key repeatedly allowed.	Setting screen display
	TIME/DATE DISPLAY	Switch display mode between OFF → time display → date display → date and time display mode and time display → OFF mode.	Switch date display/time display/off selection.	Date/time display
	DISPLAY	Display	Switch on/off.	
	TITLE	Title setting	Request setting. → Setting is started with Exec. Pressing Up/Down key repeatedly allowed.	Title setting screen display
	EXEC	Confirm title/clock settings.	Select with Up/Down and confirm with Exec.	Setting screen selection highlighted in yellow.
UP/DOWN	UP	Data UP key (priority for AE mode, Bright, manual WB, title, and clock)	Request UP.	Selection highlighted.
	DOWN	Data DOWN key (priority for AE mode, Bright, manual WB, title, and clock)	Request DOWN.	Selection highlighted.
PRESET	POS1	Recall preset position 1.	Request recall.	RECALL POS0
	POS2	Recall preset position 2.	Request recall.	RECALL POS1
	POS3	Recall preset position 3.	Request recall.	RECALL POS2
	POS4	Recall preset position 4.	Request recall.	RECALL POS3
	POS5	Recall preset position 5.	Request recall.	RECALL POS4
	POS6	Recall preset position 6.	Request recall.	RECALL POS5
	POS7	Recall custom preset.	Request recall.	RECALL
	POS PRESET	Write data. Enabled when pressed together with POS button.	Request setting. Enabled when pressed together with POS key.	PRESET display
	POS RESET	Delete data. Enabled when pressed together with POS button.	Request deletion. Enabled when pressed together with POS key.	RESET display
Others	APERTURE UP	Increase aperture (Aperture UP)	Request UP.	Aperture bar displayed for 3 s.
	AUTO SLOW SHUTTER*1	Switch Auto Slow Shutter on/off.	Switch on/off.	“ASS” (character display)
	APERTURE DOWN	Decrease aperture (Aperture DOWN)	Request DOWN.	Aperture bar displayed for 3 s.
	AF SENSITIVITY	Switch AF sensitivity between Normal and Low.	Switch between Normal and Low.	“SENS L” (character display)
	BRIGHT UP	Raise brightness setting (Bright UP) (When not in Bright mode, switching to Bright mode is made automatically depending on the conditions.)	Request UP./Pressing repeatedly allowed.	Bright bar display
	BRIGHT DOWN	Lower brightness setting (Bright DOWN) (When not in Bright mode, switching to Bright mode is made automatically depending on the conditions.)	Request DOWN./Pressing repeatedly allowed.	Bright bar display

\*1 The Freeze and Auto Slow Shutter functions are not supported by the FCB-IX45A/IX45AP.

# Initial Settings, Custom Preset and Backup

Initial settings for the various functions of the FCB-IX47A/IX47AP/IX45A/IX45AP are indicated in the “Initial settings” column.

The “Custom preset” column indicates whether the custom preset function can be used to store the settings. The function enables the stored settings to be recalled automatically when the camera is turned on. The “Standby backup” column indicates whether the data is preserved even when the camera is powered OFF. A circle “○” in this column signifies that the data is preserved. A cross “×” signifies that the data IS NOT preserved.

Mode/Position	Initial settings	Custom preset	Standby backup
Zoom Position	Wide end	○	○
D-Zoom On/Off	On	○	○
D-Zoom Separate/Combine	Combine	○	○
D-Zoom Position	00h	○	○
Focus Position	—	○	○
Focus Auto/Manual	Auto	○	○
Near Limit Setting	8000h (40cm)	○	○
AF Sensitivity	Normal	○	○
AF Mode	Normal	○	○
AF Run Time	5 sec	○	○
AF Interval	5 sec	○	○
WB Mode	Auto	○	○
WB Data (Rgain, Bgain)	—	○	○
One Push WB Data	—	○	○
AE Mode	Full Auto	○	○
Slow Shutter Mode	Manual	○	○
Shutter Position	1/60sec (NTSC), 1/50sec (PAL)	○	○
Iris Position	—	○	○
Gain Position	—	○	○
Bright Position	—	○	○
Exposure Compensation On/Off	Off	○	○
Exposure Compensation Amount	±0	○	○
Backlight On/Off	Off	○	○
Spot AE On/Off	Off	○	○
Spot AE Position Setting	X=8, Y=8	○	○
Aperture Level	5	○	○
LR Reverse On/Off	Off	○	○
Freeze On/Off	Off	×	×
Picture Effect	Off	○	○
Camera Memory	Same as the initial value setting	○	○
Display On/Off	Off	○	○
Mute On/Off	Off	×	×

Mode/Position	Initial settings	Custom preset	Standby backup
Title Display On/Off	Off	<input type="radio"/>	<input type="radio"/>
Title Setting	—	<input type="radio"/>	<input type="radio"/>
Key Lock On/Off	Off	<input type="radio"/>	<input type="radio"/>
Camera ID	0000h	<input type="radio"/>	<input type="radio"/>

**Note**

The number of times data can be written to EEPROM (by executing Custom Preset) is limited.



# Mode Condition

## Condition

Mode	Power Off	Power On	Freeze On	MemRecall
Address Set	○	○	○	○
IF_Clear	○	○	○	○
Command Cancel	○	○	○	○
Power On/Off	○	○	○	○

## Lens

Mode	Power Off	Power On	Freeze On	MemRecall	Zoom Direct	Focus Direct	ZmFo Direct	Focus Auto
Zoom Tele/Wide/Stop	×	○	×	×	×	○	×	○
Zoom Direct	×	○	×	×	○	○	×	○
Zoom Focus Direct	×	○	×	×	×	×	○	×
D-Zoom On/Off	×	○	×	×	×	○	×	○
D-Zoom Separate/Combine	×	○	×	×	×	○	×	○
D-Zoom Tele/Wide/Stop	×	○	×	×	○	○	○	○
D-Zoom ×1/Max	×	○	×	×	○	○	○	○
D-Zoom Direct	×	○	×	×	○	○	○	○
Focus Far/Near/Stop	×	○	×	×	○	×	×	×
Focus Direct	×	○	×	×	○	○	×	×
Focus Auto/Manual	×	○	×	×	○	×	×	○
One Push AF	×	○	×	×	○	×	×	×
Focus Infinity	×	○	×	×	○	×	×	○
Focus Near Limit	×	○	×	×	○	×	×	○
AF Sensitivity Normal/Low	×	○	×	×	○	○	○	○
AF Mode Norm/Interval/Zoom	×	○	×	×	○	○	○	○
AF Activation Time/Interval Setting	×	○	×	×	○	○	○	○
Camera Memory Set/Reset	×	○	○	×	×	×	×	○
Camera Memory Recall	×	○	○	○*	×	×	×	○
Lens Initialization	×	○	○	×	×	×	×	○
Comp Scan	×	○	○	×	×	×	×	○

\* × during recalling from key

## White Balance

Mode	Power Off	Initializing	Power On	Freeze On	MemRecall	WB AUTO	Indoor	Outdoor	OnePush	ATW	Manual
WB Mode Switchover	x	x	o	x	x	o	o	o	o	o	o
One Push WB	x	x	o	x	x	x	x	x	o	x	x
RGain Setting	x	x	o	x	x	x	x	x	x	x	o
BGain Setting	x	x	o	x	x	x	x	x	x	x	o

## Exposure

Mode	Power Off	Initializing	Power On	Freeze On	MemRecall	AE Full Auto	AE Manual	ShutterPriority	Iris Priority	Bright
AE Full Auto	x	x	o	x	x	o	o	o	o	o
AE Manual	x	x	o	x	x	o	o	o	o	o
Shutter Priority	x	x	o	x	x	o	o	o	o	o
Iris Priority	x	x	o	x	x	o	o	o	o	o
Bright	x	x	o	x	x	o	x	o	x	o
Shutter Setting	x	x	o	x	x	x	o	o	x	x
Iris Setting	x	x	o	x	x	x	o	x	o	x
Gain Setting	x	x	o	x	x	x	o	x	x	x
Bright Setting	x	x	o	x	x	x	x	x	x	o
Slow Shutter Auto/Manual	x	x	o	x	x	o	o	o	o	o
Exposure Compensation On/Off	x	x	o	x	x	o	o	o	o	o
Exposure Compensation Setting	x	x	o	x	x	o	o	o	o	o
Backlight On/Off	x	x	o	x	x	o	x	x	x	x
SpotAE On/Off	x	x	o	x	x	o	o	o	o	o
SpotAE Setting	x	x	o	x	x	o	o	o	o	o

## Others

Mode	Power Off	Initializing	Power On	Freeze On	MemRecall
Aperture Setting	x	x	○	x	x
LR_Reverse On/Off	x	x	○	x	x
Freeze On/Off	x	x	○	○	x
Picture Effect Setting	x	x	○	x	x
Display On/Off	x	x	○	○	○
Mute On/Off	x	x	○	○	○
Title Setting	x	x	○	○	○
Key Lock On/Off	x	x	○	○	○
ID Write	x	x	○	○	○

# Command List

---

## VISCA<sup>1)</sup>/RS-232C Commands

This Manual outlines an RS-232C control protocol and command list for certain Sony cameras from which control software can be developed.

THIS CONTROL PROTOCOL AND COMMAND LIST IS PROVIDED BY SONY ON AN “AS-IS BASIS” WITHOUT WARRANTY OF ANY KIND. SONY DOES NOT WARRANT ANY PARTICULAR RESULT FROM THE USE OF THIS CONTROL PROTOCOL AND COMMAND LIST AND DISCLAIMS AND EXCLUDES ALL WARRANTIES, EXPRESS OR IMPLIED, WITH RESPECT TO THAT CONTROL PROTOCOL AND COMMAND LIST, INCLUDING, BUT NOT LIMITED TO, ANY OR ALL IMPLIED WARRANTIES OF MERCHANTABILITY OR FITNESS FOR A PARTICULAR PURPOSE. IN FACT, SONY SPECIFICALLY ACKNOWLEDGES THAT SOFTWARE DEVELOPED BASED ON THIS CONTROL PROTOCOL AND COMMAND LIST MAY CAUSE MALFUNCTION OR DAMAGE TO HARDWARE AND SOFTWARE USED WITH IT (INCLUDING SONY HARDWARE AND SOFTWARE) AND SPECIFICALLY DISCLAIMS ANY LIABILITY FOR ANY SUCH MALFUNCTION OR DAMAGE. THIS CONTROL PROTOCOL AND COMMAND LIST SHOULD BE USED WITH CAUTION.

## Overview of VISCA

In VISCA the device outputting commands, for example, a computer, is called the controller. The device receiving the commands, an FCB-IX47A/IX47AP/IX45A/IX45AP camera is called the peripheral device. In VISCA, up to seven peripheral devices like the FCB-IX47A/IX47AP/IX45A/IX45AP camera can be connected to one controller using communication conforming to the RS-232C standard. The parameters of RS-232C are as follows:

- Communication speed: 9.6 kbps/19.2 kbps/38.4 kbps
- Data bits : 8
- Start bit : 1
- Stop bit : 1/2
- Non parity

Peripheral devices are connected in a daisy chain. As shown in the following figure, the actual internal connection is a one-direction ring, so that messages return to the controller via the peripheral devices. The devices on the network are assigned addresses. The address of the controller is fixed at 0. The addresses of the peripheral devices are 1, 2, 3 ... in order, starting from the one nearest the controller. The address of the peripheral device is set by sending address commands during the initialization of the network.

---

1) VISCA is a protocol which controls consumer camcorders developed by Sony. “VISCA” is a trademark of Sony Corporation.

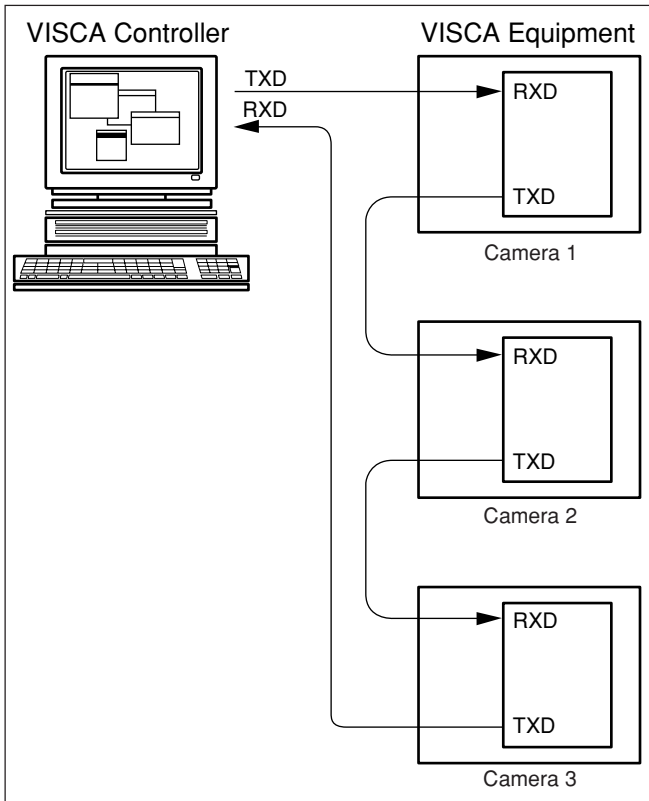

VISCA network structure

**Notes**

- Connect the serial output from the PC to the serial input of camera 1, then connect the serial output of camera 1 to the serial input of camera 2, the serial output of camera 2 to the serial input of camera 3, and the serial output of camera 3 to the serial input of the PC. (Up to seven cameras may be connected.)
- Power on all the units connected in series.
- Mixed existence of RS-232C and TTL signal levels is not allowed.

## VISCA Communication Specifications

### VISCA Packet Structure

The basic unit of VISCA communication is called a packet. The first byte of the packet is called the header and comprises the sender's and receiver's addresses. For example, the header of the packet sent to the FCB-IX47A/IX47AP/IX45A/IX45AP camera assigned address 1 from the controller (address 0) is hexadecimal 81H. The packet sent to the camera assigned address 2 is 82H. In the command list, as the header is 8X, input the address of the camera at X. The

header of the reply packet from the camera assigned address 1 is 90H. The packet from the camera assigned address 2 is A0H. Some of the commands for setting cameras can be sent to all devices at one time (broadcast). In the case of broadcast, the header should be hexadecimal 88H. When the terminator is FFH, it signifies the end of the packet.

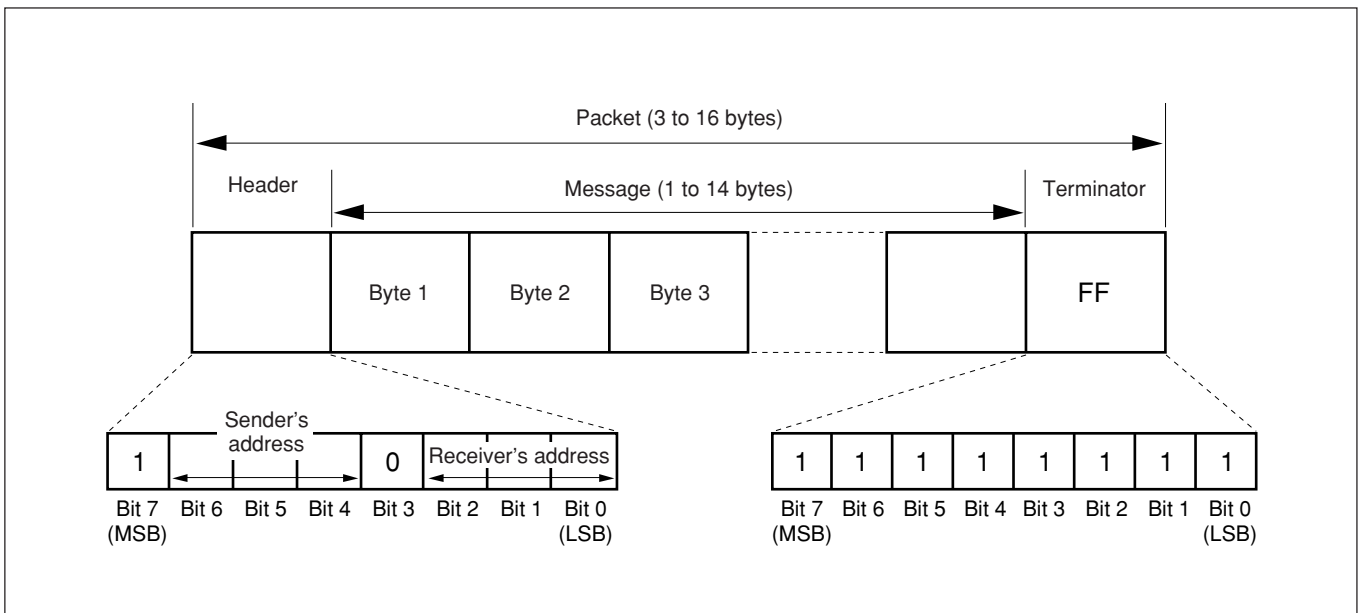

---

## Command and Inquiry

### ● Command

Sends operational commands to the FCB-IX47A/IX47AP/IX45A/IX45AP camera.

### ● Inquiry

Used for inquiring about the current state of the FCB-IX47A/IX47AP/IX45A/IX45AP camera.

	Command Packet	Note
Inquiry	8X QQ RR ... FF	QQ <sup>1)</sup> = Command/Inquiry, RR <sup>2)</sup> = category code

<sup>1)</sup> QQ = 01 (Command), 09 (Inquiry)

<sup>2)</sup> RR = 00 (Interface), 04 (camera 1), 06 (Pan/Tilter), 07 (camera 2)

X = 1 to 7: FCB-IX47A/IX47AP/IX45A/IX45AP address

---

## Responses for Commands and Inquiries

### ● ACK message

Returned by the FCB-IX47A/IX47AP/IX45A/IX45AP camera when it receives a command. No ACK message is returned for inquiries.

### ● Completion message

Returned by the FCB-IX47A/IX47AP/IX45A/IX45AP camera when execution of commands or inquiries is completed. In the case of inquiry commands, it will contain reply data for the inquiry after the 3rd byte of the packet. If the ACK message is omitted, the socket number will contain 0.

	Reply Packet	Note
Ack	X0 4Y FF	Y = socket number
Completion (commands)	X0 5Y FF	Y = socket number
Completion (Inquiries)	X0 5Y ... FF	Y = socket number

X = 9 to F: FCB-IX47A/IX47AP/IX45A/IX45AP address + 8

### ● Error message

When a command or inquiry command could not be executed or failed, an error message is returned instead of the completion message.

Error Packet	Description
X0 6Y 01 FF	Message length error (>14 bytes)
X0 6Y 02 FF	Syntax Error
X0 6Y 03 FF	Command buffer full
X0 6Y 04 FF	Command cancelled
X0 6Y 05 FF	No socket (to be cancelled)
X0 6Y 41 FF	Command not executable

X = 9 to F: FCB-IX47A/IX47AP/IX45A/IX45AP address + 8, Y = socket number

---

## Socket Number

When command messages are sent to the FCB-IX47A/IX47AP/IX45A/IX45AP camera, it is normal to send the next command message after waiting for the completion message or error message to return. However to deal with advanced uses, the camera has two buffers (memories) for commands, so that up to two commands including the commands currently being executed can be received. When the camera receives commands, it notifies the sender which command buffer was used using the socket number of the ACK message. As the completion message or error message also has a socket number, it indicates which command has ended. Even when two command buffers are being used at any one time, a camera management command and some inquiry messages can be executed. The ACK message is not returned for these commands and inquiries, and only the completion message of socket number 0 is returned.

---

## Command Execution Cancel

To cancel a command which has already been sent, send the IF\_Clear command as the next command. To cancel one of any two commands which have been sent, use the cancel message.

	Cancel Packet	Note
Cancel	8X 2Y FF	Y = socket number

X = 1 to 7: FCB-IX47A/IX47AP/IX45A/IX45AP address, Y = socket number

An error message will be returned for this command, but this is not a mistake. This message indicates that the command has been canceled.

## VISCA Device Setting Command

Before starting control of the FCB-IX47A/IX47AP/IX45A/IX45AP, be sure to send the Address command and the IF\_Clear command using the broadcast function.

---

### For VISCA Network Administration

#### ● Address

Sets an address of a peripheral device. Use when initializing the network and when receiving the network change message indicated below.

#### ● Network Change

Sent from the peripheral device to the controller when a device is removed from or added to the network. The address must be re-set when this message is received.

	Packet	Note
Address	88 30 01 FF	Always broadcasted.
Network Change	X0 38 FF	
X = 9 to F: FCB-IX47A/IX47AP/IX45A/IX45AP address + 8		

---

## VISCA Interface Command

#### ● IF\_Clear

Clears the command buffers in the FCB-IX47A/IX47AP/IX45A/IX45AP and cancels the command currently being executed.

	Command Packet	Reply Packet	Note
IF_Clear	8X 01 00 01FF	X0 50 FF	
IF_Clear (broadcast)	88 01 00 01 FF	88 01 00 01 FF	
X = 1 to 7: FCB-IX47A/IX47AP/IX45A/IX45AP address (For inquiry packet)			
X = 9 to F: FCB-IX47A/IX47AP/IX45A/IX45AP address +8 (For reply packet)			

---

## VISCA Interface and Inquiry

#### ● IF\_DeviceTypeInq

Returns information on the VISCA interface.

Inquiry	Inquiry Packet	Reply Packet	Description
IF_DeviceTypeInq	8X 09 00 02 FF	Y0 50 GG GG HH HH JJ JJ KK FF	GGGG = Vender ID (0020: Sony) HHHH = Model ID 0418=FCB-IX47A 0419=FCB-IX47AP 041A=FCB-IX45A 041B=FCB-IX45AP JJJJ = ROM revision KK = Maximum socket # (02)

X = 1 to 7: FCB-IX47A/IX47AP/IX45A/IX45AP address (For inquiry packet)

X = 9 to F: FCB-IX47A/IX47AP/IX45A/IX45AP address +8 (For reply packet)

## VISCA Command/ACK Protocol

Command	Command Message	Reply Message	Comments
General Command	81 01 04 38 02 FF (Example)	90 41 FF (ACK)+90 51 FF (Completion) 90 42 FF 90 52 FF	Returns ACK when a command has been accepted, and Completion when a command has been executed.
	81 01 04 38 FF (Example)	90 60 02 FF (Syntax Error)	Accepted a command which is not supported or a command lacking parameters.
	81 01 04 38 02 FF (Example)	90 60 03 FF (Command Buffer Full)	There are two commands currently being executed, and the command could not be accepted.
	81 01 04 08 02 FF (Example)	90 61 41 FF (Command Not Executable) 90 62 41 FF	Could not execute the command in the current mode.
Inquiry Command	81 09 04 38 FF (Example)	90 50 02 FF (Completion)	ACK is not returned for the inquiry command.
	81 09 05 38 FF (Example)	90 60 02 FF (Syntax Error)	Accepted an incompatible command.
Address Set	88 30 01 FF	88 30 02 FF	Returned the device address to +1.
IF_Clear (Broadcast)	88 01 00 01 FF	88 01 00 01 FF	Returned the same command.
IF_Clear (For x)	8x 01 00 01 FF	z0 50 FF (Completion)	ACK is not returned for this command.
Command Cancel	8x 2y FF	z0 6y 04 FF (Command Canceled)	Returned when the command of the socket specified is canceled. Completion for the command canceled is not returned.
		z0 6y 05 FF (No Socket)	Returned when the command of the specified socket has already been completed or when the socket number specified is wrong.



## VISCA Camera-Issued Messages

### ACK/Completion Messages

	Command Messages	Comments
ACK	z0 4y FF (y:Socket No.)	Returned when the command is accepted.
Completion	z0 5y FF (y:Socket No.)	Returned when the command has been executed.

z = Device address + 8

### Error Messages

	Command Messages	Comments
Syntax Error	z0 60 02 FF	Returned when the command format is different or when a command with illegal command parameters is accepted.
Command Buffer Full	z0 60 03 FF	Indicates that two sockets are already being used (executing two commands) and the command could not be accepted when received.
Command Canceled	z0 6y 04 FF (y:Socket No.)	Returned when a command which is being executed in a socket specified by the cancel command is canceled. The completion message for the command is not returned.
No Socket	z0 6y 05 FF (y:Socket No.)	Returned when no command is executed in a socket specified by the cancel command, or when an invalid socket number is specified.
Command Not Executable	z0 6y 41 FF (y:Socket No.)	Returned when a command cannot be executed due to current conditions. For example, when commands controlling the focus manually are received during auto focus.

### Network Change Message

	Command Message	Comments
Network Change	z0 38 FF	Issued when power is being routed.

# FCB-IX47A/IX47AP/IX45A/IX45AP Commands

## FCB-IX47A/IX47AP/IX45A/IX45AP Command List (1/4)

Command Set	Command	Command Packet	Comments	
AddressSet	Broadcast	88 30 01 FF		
IF_Clear	Broadcast	88 01 00 01 FF		
CommandCancel		8x 2p FF	p: Socket No.(=1or2)	
CAM_Power	On	8x 01 04 00 02 FF	Power ON/OFF	
	Off	8x 01 04 00 03 FF		
CAM_Zoom	Stop	8x 01 04 07 00 FF	p=0 (Low) to 7 (High)	
	Tele(Standard)	8x 01 04 07 02 FF		
	Wide(Standard)	8x 01 04 07 03 FF		
	Tele(Variable)	8x 01 04 07 2p FF		
	Wide(Variable)	8x 01 04 07 3p FF		
	Direct	8x 01 04 47 0p 0q 0r 0s FF		pqrs: Zoom Position
CAM_DZoom	On	8x 01 04 06 02 FF	Digital zoom ON/OFF	
	Off	8x 01 04 06 03 FF		
	Combine Mode	8x 01 04 36 00 FF	Optical/Digital Zoom Combined	
	Separate Mode	8x 01 04 36 01 FF	Optical/Digital Zoom Separate	
	Stop	8x 01 04 06 00 FF		
	Tele(Variable)	8x 01 04 06 2p FF	p=0 (Low) to 7 (High)	
	Wide(Variable)	8x 01 04 06 3p FF		
	x1/Max	8x 01 04 06 10 FF	x1/MAX Magnification Switchover	
Direct	8x 01 04 46 00 00 0p 0q FF	pq: D-Zoom Position		
CAM_Focus	Stop	8x 01 04 08 00 FF	p=0 (Low) to 7 (High)	
	Far(Standard)	8x 01 04 08 02 FF		
	Near(Standard)	8x 01 04 08 03 FF		
	Far(Variable)	8x 01 04 08 2p FF		
	Near(Variable)	8x 01 04 08 3p FF		
	Direct	8x 01 04 48 0p 0q 0r 0s FF		pqrs: Focus Position
	Auto Focus	8x 01 04 38 02 FF		AF ON/OFF
	Manual Focus	8x 01 04 38 03 FF		
	Auto/Manual	8x 01 04 38 10 FF		
	One Push Trigger	8x 01 04 18 01 FF		One Push AF Trigger
	Infinity	8x 01 04 18 02 FF		Forced infinity
	Near Limit	8x 01 04 28 0p 0q 0r 0s FF		pqrs: Focus Near Limit Position
AF Sensitivity	Normal	8x 01 04 58 02 FF	AF Sensitivity High/Low	
	Low	8x 01 04 58 03 FF		
CAM_AFMode	Normal AF	8x 01 04 57 00 FF	AF Movement Mode	
	Interval AF	8x 01 04 57 01 FF		
	Zoom Trigger AF	8x 01 04 57 02 FF		
	Active/Interval Time	8x 01 04 27 0p 0q 0r 0s FF	pq: Movement Time, rs: Interval	
CAM_ZoomFocus	Direct	8x 01 04 47 0p 0q 0r 0s 0t 0u 0v 0w FF	pqrs: Zoom Position tuvw: Focus Position	
CAM_Initialize	Lens	8x 01 04 19 01 FF	Lens Initialization Start	
	Comp Scan	8x 01 04 19 02 FF	Start of Fault Correction Movement	

## FCB-IX47A/IX47AP/IX45A/IX45AP Command List (2/4)

Command Set	Command	Command Packet	Comments
CAM_WB	Auto	8x 01 04 35 00 FF	Normal Auto
	Indoor	8x 01 04 35 01 FF	Indoor mode
	Outdoor	8x 01 04 35 02 FF	Outdoor mode
	One Push WB	8x 01 04 35 03 FF	One Push WB mode
	ATW	8x 01 04 35 04 FF	Auto Tracing White Balance
	Manual	8x 01 04 35 05 FF	Manual Control mode
	One Push Trigger	8x 01 04 10 05 FF	One Push WB Trigger
CAM_RGain	Reset	8x 01 04 03 00 FF	Manual Control of R Gain
	Up	8x 01 04 03 02 FF	
	Down	8x 01 04 03 03 FF	
	Direct	8x 01 04 43 00 00 0p 0q FF	pq: R Gain
CAM_BGain	Reset	8x 01 04 04 00 FF	Manual Control of B Gain
	Up	8x 01 04 04 02 FF	
	Down	8x 01 04 04 03 FF	
	Direct	8x 01 04 44 00 00 0p 0q FF	pq: B Gain
CAM_AE	Full Auto	8x 01 04 39 00 FF	Automatic Exposure mode
	Manual	8x 01 04 39 03 FF	Manual Control mode
	Shutter Priority	8x 01 04 39 0A FF	Shutter Priority Automatic Exposure mode
	Iris Priority	8x 01 04 39 0B FF	Iris Priority Automatic Exposure mode
	Bright	8x 01 04 39 0D FF	Bright Mode (Manual control)
CAM_SlowShutter	Auto	8x 01 04 5A 02 FF	Auto Slow Shutter ON/OFF
	Manual	8x 01 04 5A 03 FF	*1
CAM_Shutter	Reset	8x 01 04 0A 00 FF	Shutter Setting
	Up	8x 01 04 0A 02 FF	
	Down	8x 01 04 0A 03 FF	
	Direct	8x 01 04 4A 00 00 0p 0q FF	pq: Shutter Position
CAM_Iris	Reset	8x 01 04 0B 00 FF	Iris Setting
	Up	8x 01 04 0B 02 FF	
	Down	8x 01 04 0B 03 FF	
	Direct	8x 01 04 4B 00 00 0p 0q FF	pq: Iris Position
CAM_Gain	Reset	8x 01 04 0C 00 FF	Gain Setting
	Up	8x 01 04 0C 02 FF	
	Down	8x 01 04 0C 03 FF	
	Direct	8x 01 04 4C 00 00 0p 0q FF	pq: Gain Position
CAM_Bright	Reset	8x 01 04 0D 00 FF	Bright Setting
	Up	8x 01 04 0D 02 FF	
	Down	8x 01 04 0D 03 FF	
	Direct	8x 01 04 4D 00 00 0p 0q FF	pq: Bright Position
CAM_ExpComp	On	8x 01 04 3E 02 FF	Exposure Compensation ON/OFF
	Off	8x 01 04 3E 03 FF	
	Reset	8x 01 04 0E 00 FF	Exposure Compensation Amount Setting
	Up	8x 01 04 0E 02 FF	
	Down	8x 01 04 0E 03 FF	
	Direct	8x 01 04 4E 00 00 0p 0q FF	
CAM_Backlight	On	8x 01 04 33 02 FF	Back Light Compensation ON/OFF
	Off	8x 01 04 33 03 FF	
CAM_SpotAE	On	8x 01 04 59 02 FF	Spot Automatic Exposure Setting
	Off	8x 01 04 59 03 FF	
	Position	8x 01 04 29 0p 0q 0r 0s FF	pq: X (0 to F), rs: Y (0 to F)

\*1 The Slow Shutter function is not supported by the FCB-IX45A/IX45AP.

## FCB-IX47A/IX47AP/IX45A/IX45AP Command List (3/4)

Command Set	Command	Command Packet	Comments
CAM_Aperture	Reset	8x 01 04 02 00 FF	Aperture Control
	Up	8x 01 04 02 02 FF	
	Down	8x 01 04 02 03 FF	
	Direct	8x 01 04 42 00 00 0p 0q FF	pq: Aperture Gain
CAM_LR_Reverse	On	8x 01 04 61 02 FF	Mirror Image ON/OFF
	Off	8x 01 04 61 03 FF	
CAM_Freeze *1	On	8x 01 04 62 02 FF	Still Image ON/OFF
	Off	8x 01 04 62 03 FF	
CAM_PictureEffect	Off	8x 01 04 63 00 FF	Picture Effect Setting
	Neg.Art	8x 01 04 63 02 FF	
	B&W	8x 01 04 63 04 FF	
CAM_Memory	Reset	8x 01 04 3F 00 pp FF	p: Memory Number (=0 to 5)
	Set	8x 01 04 3F 01 pp FF	
	Recall	8x 01 04 3F 02 7F FF	
CAM_CUSTOM	Reset	8x 01 04 3F 00 7F FF	Starts in this mode at Power ON.
	Set	8x 01 04 3F 01 7F FF	
	Recall	8x 01 04 3F 02 7F FF	
CAM_Display	On	8x 01 04 15 02 FF (8x 01 06 06 02 FF)	Display ON/OFF
	Off	8x 01 04 15 03 FF (8x 01 06 06 03 FF)	
	On/Off	8x 01 04 15 10 FF (8x 01 06 06 10 FF)	
CAM_Date/TimeSet	Date/TimeSet	8x 01 04 70 0m 0n 0p 0q 0r 0s 0t 0u 0v 0w FF (8x 01 07 29 0m 0n 0p 0q 0r 0s 0t 0u 0v 0w FF)	mn: Year (20mn) pq: Month, rs: Day tu: Hour, vw: Minute
CAM_DateDisplay	On	8x 01 04 71 02 FF (8x 01 07 2A 02 FF)	Date display ON/OFF
	Off	8x 01 04 71 03 FF (8x 01 07 2A 03 FF)	
CAM_TimeDisplay	On	8x 01 04 72 02 FF (8x 01 07 2B 02 FF)	Time display ON/OFF
	Off	8x 01 04 72 03 FF (8x 01 07 2B 03 FF)	
CAM_Title	Title Set1	8x 01 04 73 00 mm nn pp qq 00 00 00 00 00 00 FF	mm: Vposition, nn: Hposition pp: Color, qq: Blink
	Title Set2	8x 01 04 73 01 mm nn pp qq rr ss tt uu vv ww FF	mnpqrstuvw: Setting of Display Characters (1st to 10st Character)
	Title Set3	8x 01 04 73 02 mm nn pp qq rr ss tt uu vv ww FF	mnpqrstuvw: Setting of Display Characters (11th to 20th Character)
	Title Clear	8x 01 04 74 00 FF	Title Setting Clear
	On	8x 01 04 74 02 FF	Title Display ON/OFF
	Off	8x 01 04 74 03 FF	
CAM_Mute	On	8x 01 04 75 02 FF	Mute ON/OFF
	Off	8x 01 04 75 03 FF	
	On/Off	8x 01 04 75 10 FF	
CAM_KEY Lock	Off	8x 01 04 17 00 FF	Camera control on/off
	On	8x 01 04 17 02 FF	
CA_ID Write		8x 01 04 22 0p 0q 0r 0s FF	pqrs: Camera ID (0000~FFFF)

\*1 The Freeze function is not supported by the FCB-IX45A/IX45AP.

## FCB-IX47A/IX47AP/IX45A/IX45AP Inquiry Command List (1/2)

Inquiry Command	Command Packet	Inquiry Packet	Comments
CAM_PowerInq	8x 09 04 00 FF	y0 50 02 FF	On
		y0 50 03 FF	Off
CAM_ZoomPosInq	8x 09 04 47 FF	y0 50 0p 0q 0r 0s FF	pqrs: Zoom Position
CAM_DZoomModeInq	8x 09 04 06 FF	y0 50 02 FF	D-Zoom On
		y0 50 03 FF	D-Zoom Off
CAM_DZoomC/SModeInq	8x 09 04 36 FF	y0 50 00 FF	Combine Mode
		y0 50 01 FF	Separate Mode
CAM_DZoomPosInq	8x 09 04 46 FF	y0 50 00 00 0p 0q FF	pq: D-Zoom Position
CAM_FocusModeInq	8x 09 04 38 FF	y0 50 02 FF	Auto Focus
		y0 50 03 FF	Manual Focus
CAM_FocusPosInq	8x 09 04 48 FF	y0 50 0p 0q 0r 0s FF	pqrs: Focus Position
CAM_FocusNearLimitInq	8x 09 04 28 FF	y0 50 0p 0q 0r 0s FF	pqrs: Focus Near Limit Position
CAM_AFSensitivityInq	8x 09 04 58 FF	y0 50 02 FF	AF Sensitivity Normal
		y0 50 03 FF	AF Sensitivity Low
CAM_AFModeInq	8x 09 04 57 FF	y0 50 00 FF	Normal AF
		y0 50 01 FF	Interval AF
		y0 50 02 FF	Zoom Trigger AF
CAM_AFTimeSettingInq	8x 09 04 27 FF	y0 50 0p 0q 0r 0s FF	pq: Movement Time, rs: Interval
CAM_WBModeInq	8x 09 04 35 FF	y0 50 00 FF	Auto
		y0 50 01 FF	In Door
		y0 50 02 FF	Out Door
		y0 50 03 FF	One Push WB
		y0 50 04 FF	ATW
		y0 50 05 FF	Manual
CAM_RGainInq	8x 09 04 43 FF	y0 50 00 00 0p 0q FF	pq: R Gain
CAM_BGainInq	8x 09 04 44 FF	y0 50 00 00 0p 0q FF	pq: B Gain
CAM_AEModeInq	8x 09 04 39 FF	y0 50 00 FF	Full Auto
		y0 50 03 FF	Manual
		y0 50 0A FF	Shutter Priority
		y0 50 0B FF	Iris Priority
		y0 50 0D FF	Bright
CAM_SlowShutterModeInq *1	8x 09 04 5A FF	y0 50 02 FF	Auto
		y0 50 03 FF	Manual
CAM_ShutterPosInq	8x 09 04 4A FF	y0 50 00 00 0p 0q FF	pq: Shutter Position
CAM_IrisPosInq	8x 09 04 4B FF	y0 50 00 00 0p 0q FF	pq: Iris Position
CAM_GainPosInq	8x 09 04 4C FF	y0 50 00 00 0p 0q FF	pq: Gain Position
CAM_BrightPosInq	8x 09 04 4D FF	y0 50 00 00 0p 0q FF	pq: Bright Position
CAM_ExpCompModeInq	8x 09 04 3E FF	y0 50 02 FF	On
		y0 50 03 FF	Off
CAM_ExpCompPosInq	8x 09 04 4E FF	y0 50 00 00 0p 0q FF	pq: ExpComp Position
CAM_BacklightModeInq	8x 09 04 33 FF	y0 50 02 FF	On
		y0 50 03 FF	Off
CAM_SpotAEModeInq	8x 09 04 59 FF	y0 50 02 FF	On
		y0 50 03 FF	Off
CAM_SpotAEPosInq	8x 09 04 29 FF	y0 50 0p 0q 0r 0s FF	pq: X position, rs: Y position
CAM_ApertureInq	8x 09 04 42 FF	y0 50 00 00 0p 0q FF	pq: Aperture Gain

\*1 The Slow Shutter function is not supported by the FCB-IX45A/IX45AP.

## FCB-IX47A/IX47AP/IX45A/IX45AP Inquiry Command List (2/2)

Inquiry Command	Command Packet	Inquiry Packet	Comments
CAM_LR_ReverseModeInq	8x 09 04 61 FF	y0 50 02 FF	On
		y0 50 03 FF	Off
CAM_FreezeModeInq *1	8x 09 04 62 FF	y0 50 02 FF	On
		y0 50 03 FF	Off
CAM_PictureEffectModeInq	8x 09 04 63 FF	y0 50 00 FF	Off
		y0 50 02 FF	Neg.Art
		y0 50 04 FF	B&W
CAM_MemoryInq	8x 09 04 3F FF	y0 50 pp FF	pp: Last Recall Memory No.
CAM_DisplayModeInq	8x 09 04 15 FF (8x 09 06 06 FF)	y0 50 02 FF	On
		y0 50 03 FF	Off
CAM_TitleDisplayModeInq	8x 09 04 74 FF	y0 50 02 FF	On
		y0 50 03 FF	Off
CAM_MuteModeInq	8x 09 04 75 FF	y0 50 02 FF	On
		y0 50 03 FF	Off
CAM_KeyLockInq	8x 09 04 17 FF	y0 50 00 FF	Off
		y0 50 02 FF	On
CAM_IDInq	8x 09 04 22 FF	y0 50 0p 0q 0r 0s FF	pqrs: Camera ID

\*1 The Freeze function is not supported by the FCB-IX45A/IX45AP.

## FCB-IX47A/IX47AP/IX45A/IX45AP Block Inquiry Command List

## Lens Control System Inquiry Commands (1/2) ..... Command Packet 8x 09 7E 7E 00 FF

Byte	Bit	Comments
0	7	Destination Address
	6	
	5	
	4	
	3	Source Address
	2	
	1	
	0	
1	7	0 Completion Message (50h)
	6	1
	5	0
	4	1
	3	0
	2	0
	1	0
	0	0
2	7	0
	6	0
	5	0
	4	0
	3	Zoom Position (HH)
	2	
	1	
	0	
3	7	0
	6	0
	5	0
	4	0
	3	Zoom Position (HL)
	2	
	1	
	0	
4	7	0
	6	0
	5	0
	4	0
	3	Zoom Position (LH)
	2	
	1	
	0	
5	7	0
	6	0
	5	0
	4	0
	3	Zoom Position (LL)
	2	
	1	
	0	

Byte	Bit	Comments
6	7	0
	6	0
	5	0
	4	0
	3	Focus Near Limit (H)
	2	
	1	
	0	
7	7	0
	6	0
	5	0
	4	0
	3	Focus Near Limit (L)
	2	
	1	
	0	
8	7	0
	6	0
	5	0
	4	0
	3	Focus Position (HH)
	2	
	1	
	0	
9	7	0
	6	0
	5	0
	4	0
	3	Focus Position (HL)
	2	
	1	
	0	
10	7	0
	6	0
	5	0
	4	0
	3	Focus Position (LH)
	2	
	1	
	0	
11	7	0
	6	0
	5	0
	4	0
	3	Focus Position (LL)
	2	
	1	
	0	

---

**Lens Control System Inquiry Commands (2/2) ..... Command Packet 8x 09 7E 7E 00 FF**

Byte	Bit	Comments
12	7	0
	6	0
	5	0
	4	0
	3	0
	2	0
	1	0
	0	0
13	7	0
	6	0
	5	DZoomMode 1: Separate 0: Combine
	4	AF Mode
	3	0: Normal 1: Interval 2: Zoom Trigger
	2	AF Sensitivity 1: Normal 0: Slow
	1	Digital Zoom 1:On 0:Off
	0	Focus Mode 1:Auto 0:Manual
14	7	0
	6	0
	5	0
	4	0
	3	Low Contrast Detection 1: Yes 0: No
	2	Camera Memory Recall 1: Executing 0: Stopped
	1	Focus Command 1: Executing 0: Stopped
	0	Zoom Command 1: Executing 0: Stopped
15	7	1 Terminator (FFh)
	6	1
	5	1
	4	1
	3	1
	2	1
	1	1
	0	1



## Camera Control System Inquiry Commands (1/2).. Command Packet 8x 09 7E 7E 01 FF

Byte	Bit	Comments
0	7	Destination Address
	6	
	5	
	4	
	3	Source Address
	2	
	1	
	0	
1	7	0 Completion Message (50h)
	6	1
	5	0
	4	1
	3	0
	2	0
	1	0
	0	0
2	7	0
	6	0
	5	0
	4	0
	3	R Gain (H)
	2	
	1	
	0	
3	7	0
	6	0
	5	0
	4	0
	3	R Gain (L)
	2	
	1	
	0	
4	7	0
	6	0
	5	0
	4	0
	3	B Gain (H)
	2	
	1	
	0	
5	7	0
	6	0
	5	0
	4	0
	3	B Gain (L)
	2	
	1	
	0	

Byte	Bit	Comments
6	7	0
	6	0
	5	0
	4	0
	3	0
	2	WB Mode
	1	
	0	
7	7	
	6	0
	5	0
	4	0
	3	Aperture Gain
	2	
	1	
	0	
8	7	0
	6	0
	5	0
	4	Exposure Mode
	3	
	2	
	1	
	9	7
6		0
5		0
4		0
3		Spot AE 1: On 0: Off
2		Back Light 1:On 0:Off
1		Exposure Comp. 1:On 0:Off
0		Slow Shutter 1:Auto 0:Manual
10	7	0
	6	0
	5	0
	4	Shutter Position
	3	
	2	
	1	
	11	7
6		0
5		0
4		Iris Position
3		
2		
1		
0		

---

**Camera Control System Inquiry Commands (2/2) Command Packet 8x 09 7E 7E 01 FF**

Byte	Bit	Comments
12	7	0
	6	0
	5	0
	4	0
	3	Gain Position
	2	
	1	
	0	
0		
13	7	0
	6	0
	5	0
	4	Bright Position
	3	
	2	
	1	
	0	
14	7	0
	6	0
	5	0
	4	0
	3	Exposure Comp. Position
	2	
	1	
	0	
0		
15	7	1 Terminator (FFh)
	6	1
	5	1
	4	1
	3	1
	2	1
	1	1
	0	1

**Other Inquiry Commands (1/2)..... Command Packet 8x 09 7E 7E 02 FF**

Byte	Bit	Comments
0	7	Destination Address
	6	
	5	
	4	
	3	Source Address
	2	
	1	
	0	
1	7	0 Completion Message (50h)
	6	1
	5	0
	4	1
	3	0
	2	0
	1	0
	0	0
2	7	0
	6	0
	5	0
	4	0
	3	0
	2	0
	1	Key Lock 1: On 0: Off
	0	Power 1:On 0:Off
3	7	0
	6	0
	5	0
	4	0
	3	Freeze 1:On 0:Off
	2	LR Reverse 1:On 0:Off
	1	0
	0	0
4	7	0
	6	0
	5	0
	4	Mute 1: On 0: Off
	3	Title Display 1: On 0: Off
	2	Display 1: On 0: Off
	1	0
	0	0
5	7	0
	6	0
	5	0
	4	0
	3	Picture Effect Mode
	2	
	1	
	0	

Byte	Bit	Comments
6	7	0
	6	0
	5	0
	4	0
	3	0
	2	0
	1	0
	0	0
7	7	0
	6	0
	5	0
	4	0
	3	0
	2	0
	1	0
	0	0
8	7	0
	6	0
	5	0
	4	0
	3	Camera ID (HH)
	2	
	1	
	0	
9	7	0
	6	0
	5	0
	4	0
	3	Camera ID (HL)
	2	
	1	
	0	
10	7	0
	6	0
	5	0
	4	0
	3	Camera ID (LH)
	2	
	1	
	0	
11	7	0
	6	0
	5	0
	4	0
	3	Camera ID (LL)
	2	
	1	
	0	

---

**Other Inquiry Commands (2/2)..... Command Packet 8x 09 7E 7E 02 FF**

Byte	Bit	Comments
12	7	0
	6	0
	5	External Lock 1: Provided 0: Not provided
	4	Memory 1: Provided 0: Not provided
	3	Clock 1: Provided 0: Not provided
	2	0
	1	0
	0	System 1:PAL 0:NTSC
13	7	0
	6	0
	5	0
	4	0
	3	V-Phase (H)
	2	
	1	
	0	
0		
14	7	0
	6	0
	5	0
	4	0
	3	V-Phase (L)
	2	
	1	
	0	
0		
15	7	1 Terminator (FFh)
	6	1
	5	1
	4	1
	3	1
	2	1
	1	1
	0	1

**Enlargement Function Query Command (1/2) ..... Command Packet 8x 09 7E 7E 03 FF**

Byte	Bit	Comments
0	7	Destination Address
	6	
	5	
	4	
	3	Source Address
	2	
	1	
	0	
1	7	0 Completion Message (50h)
	6	1
	5	0
	4	1
	3	0
	2	0
	1	0
	0	0
2	7	0
	6	0
	5	0
	4	0
	3	Digital Zoom Position (H)
	2	
	1	
	0	
3	7	0
	6	0
	5	0
	4	0
	3	Digital Zoom Position (L)
	2	
	1	
	0	
4	7	0
	6	0
	5	0
	4	0
	3	AF Activation Time (H)
	2	
	1	
	0	
5	7	0
	6	0
	5	0
	4	0
	3	AF Activation Time (L)
	2	
	1	
	0	

Byte	Bit	Comments
6	7	0
	6	0
	5	0
	4	0
	3	AF Interval Time (H)
	2	
	1	
	0	
7	7	0
	6	0
	5	0
	4	0
	3	AF Interval Time (L)
	2	
	1	
	0	
8	7	0
	6	0
	5	0
	4	0
	3	SpotAE Position (X)
	2	
	1	
	0	
9	7	0
	6	0
	5	0
	4	0
	3	SpotAE Position (Y)
	2	
	1	
	0	
10	7	0
	6	0
	5	0
	4	0
	3	0
	2	0
	1	0
	0	0
11	7	0
	6	0
	5	0
	4	0
	3	0
	2	0
	1	0
	0	0

---

**Enlargement Function Query Command (2/2) ..... Command Packet 8x 09 7E 7E 03 FF**

Byte	Bit	Comments
12	7	0
	6	0
	5	0
	4	0
	3	0
	2	0
	1	0
	0	0
13	7	0
	6	0
	5	0
	4	0
	3	0
	2	0
	1	0
	0	0
14	7	0
	6	0
	5	0
	4	0
	3	0
	2	0
	1	0
	0	0
15	7	1 Terminator (FFh)
	6	1
	5	1
	4	1
	3	1
	2	1
	1	1
	0	1

# VISCA Command Setting Values

## Exposure Control (1/2)

		NTSC	PAL
Shutter Speed	15	10000	10000
	14	6000	6000
	13	4000	3500
	12	3000	2500
	11	2000	1750
	10	1500	1250
	0F	1000	1000
	0E	725	600
	0D	500	425
	0C	350	300
	0B	250	215
	0A	180	150
	09	125	120
	08	100	100
	07	90	75
	06	60	50
	05	30	25
	04	15	12
	03	8	6
	02	4	3
01	2	2	
00	1	1	
Iris	11	F1.4	
	10	F1.6	
	0F	F2.0	
	0E	F2.4	
	0D	F2.8	
	0C	F3.4	
	0B	F4.0	
	0A	F4.8	
	09	F5.6	
	08	F6.8	
	07	F8.0	
	06	F9.6	
	05	F11	
	04	F14	
	03	F16	
	02	F19	
01	F22		
00	CLOSE		

Gain	0F	28 dB
	0E	26 dB
	0D	24 dB
	0C	22 dB
	0B	20 dB
	0A	18 dB
	09	16 dB
	08	14 dB
	07	12 dB
	06	10 dB
	05	8 dB
	04	6 dB
	03	4 dB
	02	+2 dB
	01	0
	00	-3 dB

## Reference (Values for FCB-EX480L/ EX480L)

		NTSC	PAL
Shutter speed	13	10000	10000
	12	6000	6000
	11	4000	3500
	10	3000	2500
	0F	2000	1750
	0E	1500	1250
	0D	1000	1000
	0C	725	600
	0B	500	425
	0A	350	300
	09	250	215
	08	180	150
	07	125	120
	06	100	100
	05	90	75
	04	60	50
03	30	25	
02	15	12	
01	8	6	
00	4	3	
Gain	07	+18 dB	
	06	+15 dB	
	05	+12 dB	
	04	+9 dB	
	03	+6 dB	
	02	+3 dB	
	01	0	
	00	-3 dB	

**Exposure Control (2/2)**

		<b>IRIS</b>	<b>GAIN</b>
Bright	1F	F1.4	28 dB
	1E	F1.4	26 dB
	1D	F1.4	24 dB
	1C	F1.4	22 dB
	1B	F1.4	20 dB
	1A	F1.4	18 dB
	19	F1.4	16 dB
	18	F1.4	14 dB
	17	F1.4	12 dB
	16	F1.4	10 dB
	15	F1.4	8 dB
	14	F1.4	6 dB
	13	F1.4	4 dB
	12	F1.4	2 dB
	11	F1.4	0
	10	F1.6	0
	0F	F2.0	0
	0E	F2.4	0
	0D	F2.8	0
	0C	F3.4	0
	0B	F4.0	0
	0A	F4.8	0
	09	F5.6	0
	08	F6.8	0
	07	F8.0	0
	06	F9.6	0
	05	F11	0
	04	F14	0
	03	F16	0
	02	F19	0
01	F22	0	
00	CLOSE	0	
Exposure Comp.	0E	7	10.5 dB
	0D	6	9 dB
	0C	5	7.5 dB
	0B	4	6 dB
	0A	3	4.5 dB
	09	2	3 dB
	08	1	1.5 dB
	07	0	0 dB
	06	-1	-1.5 dB
	05	-2	-3 dB
	04	-3	-4.5 dB
	03	-4	-6 dB
	02	-5	-7.5 dB
	01	-6	-9 dB
	00	-7	-10.5 dB

**Reference (Values for FCB-EX480L/  
EX480L)**

		<b>IRIS</b>	<b>GAIN</b>
Brightness	17	1.4	+18 dB
	16	1.4	+15 dB
	15	1.4	+12 dB
	14	1.4	+9 dB
	13	1.4	+6 dB
	12	1.4	+3 dB



---

**Zoom Ratio and Zoom Position  
(for reference)**

<b>Zoom Ratio ×18 Lens</b>	<b>Optical Zoom Position Data</b>
×1	0000
×2	1606
×3	2151
×4	2860
×5	2CB5
×6	3060
×7	32D3
×8	3545
×9	3727
×10	38A9
×11	3A42
×12	3B4B
×13	3C85
×14	3D75
×15	3E4E
×16	3EF7
×17	3FA0
×18	4000

**X18-NTSC****X18-PAL**

<b>Digital Zoom Ratio</b>	<b>Digital Zoom Position Data</b>	<b>Digital Zoom Position Data</b>
×1	4000	4000
×2	6000	5E80
×3	6A80	6880
×4	7000	6DC0
×5	7340	70C0
×6	7540	72C0
×7	76C0	7440
×8	7800	7540
×9	7900	7600
×10	7980	76C0
×11	7A40	7740
×12	7AC0	77C0

## Lens Control

Zoom Position	0000	to	4000	to	7000
	Wide end		Optical Tele end		Digital Tele end
Focus Position	1000	to	C000		
	Far end		Near end		
Focus Near Limit	1000: Over Inf 2000: 8.0 m 3000: 3.5 m 4000: 2.0 m 5000: 1.4 m 6000: 1 m 7000: 80 cm 8000: 29 cm 9000: 10 cm A000: 4.7 cm B000: 2.3 cm C000: 1.0 cm		As the distance on the left will differ due to temperature characteristics, etc., use as approximate values. * The lower 1 byte is fixed at 00.		

## Others

R,B gain	00~FF
Aperture	00~0F

## Title Setting

Vposition	00 to 0A	
Hposition	00 to 17	
Blink	00: Does not blink	
	01: Blinks	
Color	00	White
	01	Yellow
	02	Violet
	03	Red
	04	Cyan
	05	Green
	06	Blue

00	01	02	03	04	05	06	07
A	B	C	D	E	F	G	H
08	09	0a	0b	0c	0d	0e	0f
I	J	K	L	M	N	O	P
10	11	12	13	14	15	16	17
Q	R	S	T	U	V	W	X
18	19	1a	1b	1c	1d	1e	1f
Y	Z	&		?	!	1	2
20	21	22	23	24	25	26	27
3	4	5	6	7	8	9	0
28	29	2a	2b	2c	2d	2e	2f
À	È	Ì	Ò	Ù	Á	É	Í
30	31	32	33	34	35	36	37
Ó	Ú	Â	Ê	Ô	Æ	Œ	Ã
38	39	3a	3b	3c	3d	3e	3f
Õ	Ñ	Ç	ß	Ä	Ï	Ö	Û
40	41	42	43	44	45	46	47
Å	\$	₣	¥	DM	£	ı	ı
48	49	4a	4b	4c	4d	4e	4f
ø	“	:	‘	.	,	/	-

# Specifications

Image sensor	$\frac{1}{4}$ type Super HAD CCD	White balance	AUTO, ATW, Indoor, Outdoor, One Push WB, Manual WB
Picture elements	FCB-IX47A/IX45A: Approx. 380K pixels (768 (H) $\times$ 494 (V)) FCB-IX47AP/IX45AP: Approx. 440K pixels (752 (H) $\times$ 582 (V))	Gain	Auto/Manual (-3 to 28 dB, 2 dB steps)
Horizontal resolution	NTSC: 470 TV lines (WIDE end) PAL: 460 TV lines (WIDE end)	Aperture control	16 steps
Lens	18 $\times$ zoom F= 4.1 mm (WIDE) to 73.8 mm (TELE), F1.4 to F3.0 Zoom movement (300 m) speed Optical WIDE/Optical TELE 2.1 s Optical WIDE/Digital TELE 3.7 s Digital WIDE/Digital TELE 1.7 s $\infty$ to Near 0.5 s	Focus	Auto (H, L), On-Push AF, Manual, Infinity Interval AF, Zoom Trigger AF
Digital zoom	4 $\times$ (72 $\times$ with optical zoom)	Preset	6 positions
Angle of view (H)	48 degree (WIDE end) to 2.7 degree (TELE end)	Serial interface	VISCA protocol (TTL/RS-232C signal level) 9.6 Kbps, 19.2 Kbps, 38.4 Kbps, Stop bit, 1/2 bit (switchable)
Min. working distance	10 mm (WIDE end), 800 mm (TELE end)	Video Output	VBS: 1.0 Vp-p (Sync negative), Y/C Output
Sync system	Internal	Storage temperature/Humidity	-20 to 60 $^{\circ}$ C (-4 to 140 $^{\circ}$ F)/20 to 95 %
Min. illumination	1.0 lux (F1.4, $\frac{1}{60}$ s (NTSC) or $\frac{1}{50}$ s (PAL)) 0.07 lux (F1.4, $\frac{1}{4}$ s (NTSC) or $\frac{1}{3}$ s (PAL))	Operating temperature/Humidity	0 to 50 $^{\circ}$ C (32 to 122 $^{\circ}$ F)/20 to 80 %
Recommended illumination	100 to 100,000 lux	Power requirements/Power consumption	6 to 12 V DC/1.5 W (2.5 W with active motors)
S/N ratio	50 dB or more	Weight	170 g (5 oz.)
Back light compensation	ON/OFF	Dimensions	48.2 $\times$ 56.6 $\times$ 92.3 mm (1 $\frac{15}{16}$ $\times$ 2 $\frac{1}{4}$ $\times$ 3 $\frac{3}{4}$ in.) (w/h/d)
Electronic shutter speed	FCB-IX47A/IX47AP: $\frac{1}{1}$ to $\frac{1}{10,000}$ s (22 steps) FCB-IX45A: $\frac{1}{60}$ to $\frac{1}{10,000}$ s (16 steps) FCB-IX45AP: $\frac{1}{50}$ to $\frac{1}{10,000}$ s (16 steps)	Design and specifications are subject to change without notice.	

Dimensions

Front

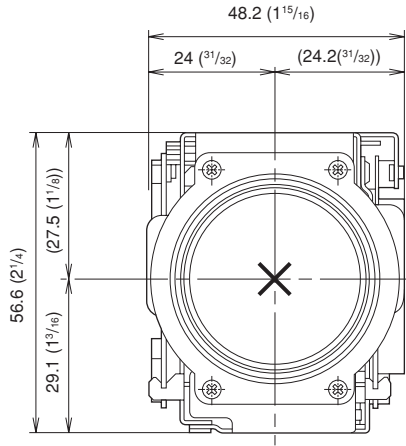

Right side

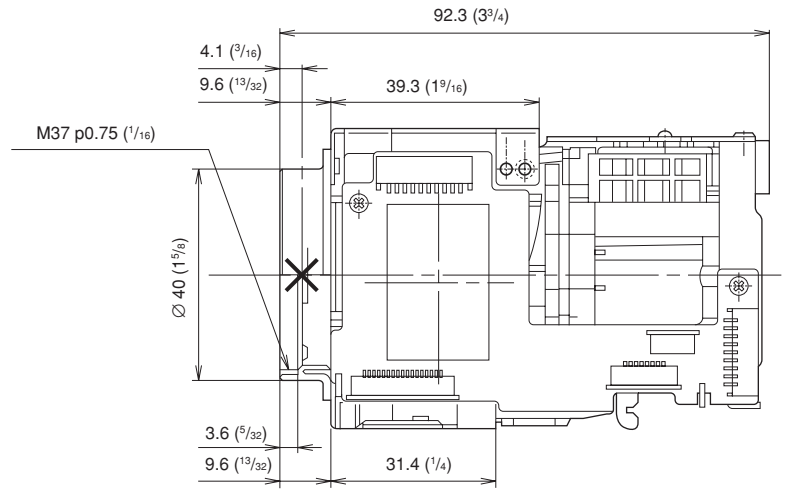

Top

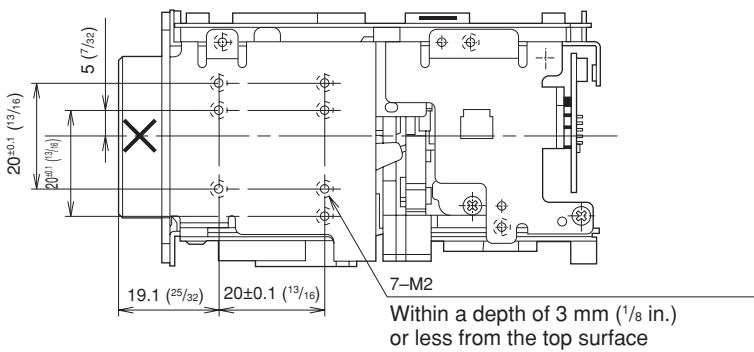

Left side

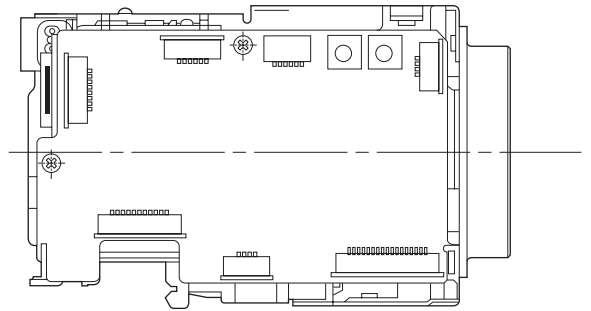

Bottom

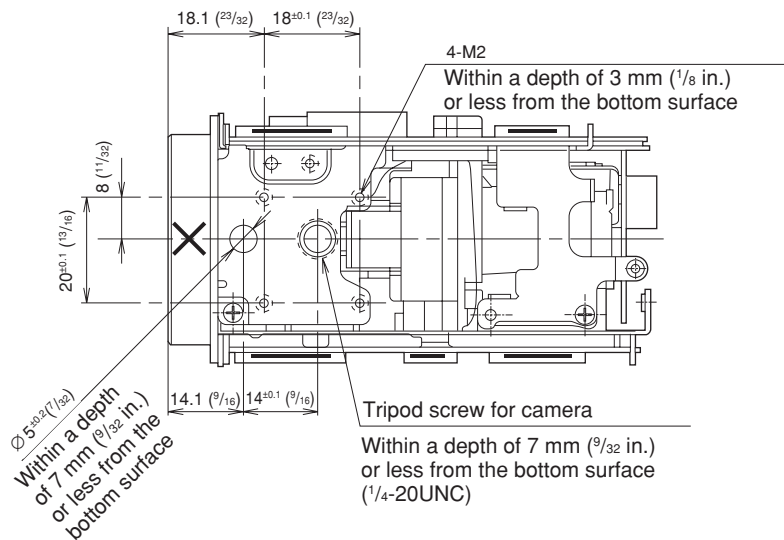

Back

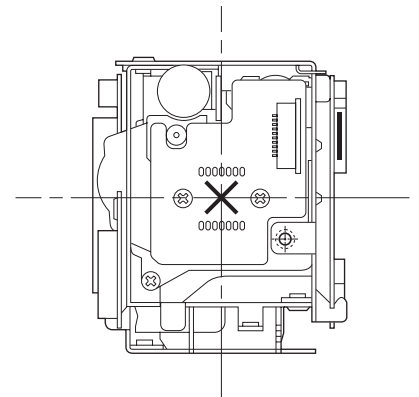

Unit: mm (inches)

Pin assignment

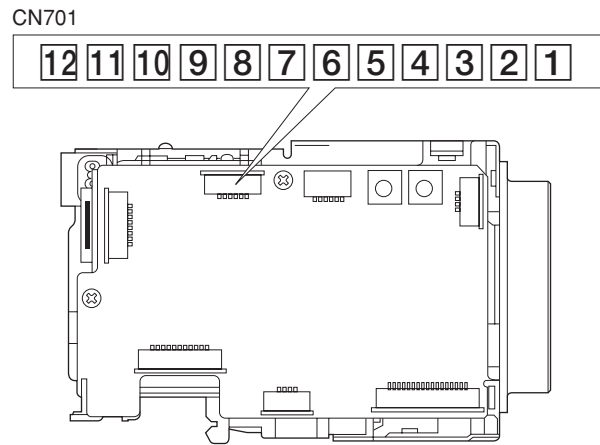
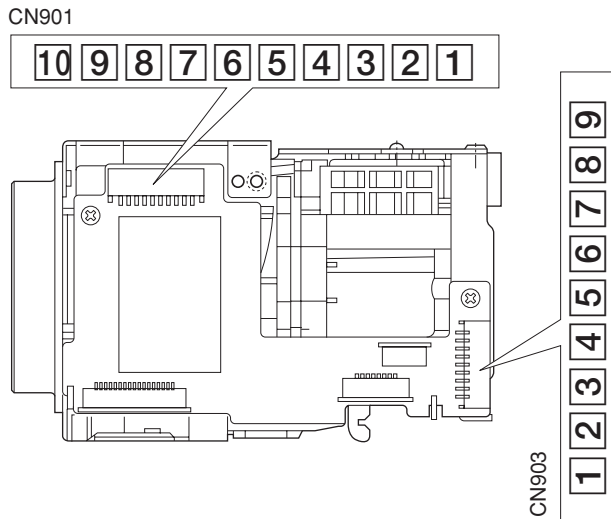

**CN901 (for communications)**

Pin No.	Name	Level
1	TxD IN	RS-232C level
2	NC	
3	NC	
4	RxD IN	RS-232C level
5	TD	TTL level
6	NC	
7	NC	
8	RD	TTL level
9	GND	
10	NC	

Connector type: JST S10B-ZR-SM3A-TF

**CN701 (for FFC cable)**

Pin No.	Name	Level
1	GND	
2	GND	
3	KEY_AD0	
4	KEY_AD1	
5	KEY_AD2	
6	KEY_AD3	
7	KEY_AD4	
8	KEY_AD5	
9	KEY_AD6	
10	KEY_AD7	
11	NC	
12	Strobe	

Connector type: Molex 52689-1240 FFC (0.5 mm)

**CN903 (for DC and video)**

Pin No.	Name	Level
1	DC IN	6V to 12V
2	GND (for DC IN)	
3	NC	
4	VBS OUT	Composite video signal
5	GND (For VBS OUT)	
6	Y-Out	
7	GND (For Y)	
8	C-Out	
9	GND (For C)	

Connector type: JST S9B-ZR-SM3A-TF

**Strobe signal specifications**

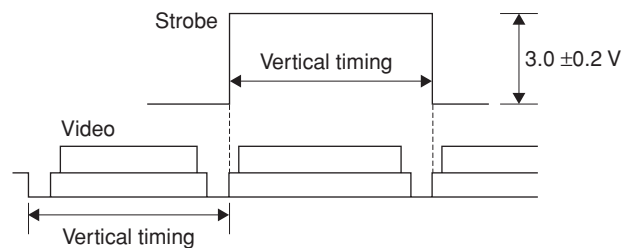

# Precautions

---

## Software

Use of the demonstration software developed by Sony Corporation or use of the software with customer developed application software may damage hardware, the application program or the camera. Sony Corporation is not liable for any damages under these conditions.

---

## Operation

Start the camera control software on your computer after you turn on the camera and the image is displayed.

---

## Operation and Storage Locations

Do not shoot images that are extremely bright (e.g., light sources, the sun, etc.) for long periods of time. Do not use or store the camera in the following extreme conditions:

- Extremely hot or cold places (operating temperature 0 °C to +40 °C (32 °F to 104 °F))
- Close to generators of powerful electromagnetic radiation such as radio or TV transmitters
- Where it is subject to fluorescent light reflections
- Where it is subject to unstable (flickering, etc.) lighting conditions
- Where it is subject to strong vibration

---

## Care of the Unit

Remove dust or dirt on the surface of the lens with a blower (commercially available).

---

## Other

Do not apply excessive voltage. (Use only the specified voltage.) Otherwise, you may get an electric shock or a fire may occur.

In case of abnormal operation, contact your authorized Sony dealer or the store where you purchased the product.